

Coaxial Connectors and Cable Accessories



A major manufacturer of coaxial cable assemblies seeks partnerships with other companies to expand its technologies into new applications.

Developed for automotive antenna applications, the technologies described herein offer several innovative features—particularly a superior price-to-performance ratio—that may benefit a wide variety of commercial applications.



Available Technologies

Connectors

- Plug Designs • 5
- Additional Plug Components • 9
- Sockets • 12

Accessories

- Cable Ground and Support • 14
- Low Insertion Force Grommets • 15
- Angled Cable Clamps • 16
- Alignment Guides for Right Angle Duplex Sockets • 16
- Cable Anchors to Eliminate Taping • 17

Commercial Applications

These connector and accessory technologies can be applied to a variety of commercial applications. Although the potential applications vary for each technology, manufacturers of connectors and accessories for the following products can benefit from technologies described in this document:

Vehicles

- Aircraft
- Automobiles
- Boats

Equipment

- Construction equipment
- Industrial equipment
- Instrumentation and test equipment
- Lawn and garden equipment

Electronics

- Cellular telephones
- Digital satellite radios
- Global positioning systems
- Medical connectors
- Modem cables
- Printed circuit boards
- Television cables

Licensing

Benefits of Licensing

A company that licenses any of these technologies will benefit in several ways.

- **Low cost:** The technology developer has invested in engineering, manufacturing, and testing the designs for its own high-volume production. Hence, a licensee can sell a new product or improve an existing one for less than it would cost to start from scratch. In addition, these technologies were developed using Design for Assembly (DFA) and Design for Manufacture (DFM) philosophies.
- **Low risk:** Many of the designs are fully developed, tested, and proven. In addition, many already have failure modes and effect analysis, parts list, detailed computer-aided design (CAD) drawings, finite element analysis (FEA) models, tooling, design modifications, and a testing and service history.
- **High performance:** All designs meet stringent mechanical, electrical, and environmental testing requirements.
- **Strategic advantage:** Companies without full engineering, development, and testing capabilities can augment their capabilities by partnering with the licensor.
- **Competitive advantage:** All of the designs have been patented, which gives the licensee an advantage over competitors.
- **High quality:** Among other distinctions, the technology developer is QS-9000/ISO-9000 certified and is committed to achieving the highest level of quality in its products.

The Licensor

The developer of these technologies is a global market leader in automotive interconnect products used in antenna connections, engine controls, and many other applications. The company is committed to customer satisfaction at world-class levels of excellence. It achieves and maintains high quality, provides quick response, keeps costs low, and encourages ongoing innovation.

Located in the northeastern United States and Puerto Rico, the company's multiple manufacturing and engineering plants provide:

- Design and development capabilities
- In-house tooling and equipment
- Automated manufacturing at multiple locations
- Quick turnaround prototype capabilities
- Insert molding, wire drawing, metal forming, injection molding, and plating equipment
- Application engineering support
- 30 years of interconnect experience

These capabilities can be used by the licensee in transferring these designs to other products.

Partnership Options

The technology developer is interested in partnering with companies selling into both automotive and nonautomotive applications. The technology developer will be an active partner, offering the licensee technical support in its product development efforts. Companies are encouraged to consider entering into one of the following partnership arrangements:

- **Patent licenses:** Manufacturers could expand their product line by adopting these technologies.
- **Cooperative development:** This arrangement allows manufacturers to expand the capabilities of their existing technologies in partnership with a market leader.
- **Strategic partnership:** Based on excess manufacturing capability of the technology developer, distribution and sales companies could sell the connectors, connector kits, and cable accessories and/or build cable assembly products.



For More Information

If your company is interested in these technologies or would like samples and general specifications, please contact:

Mark D. Obenshain
Research Triangle Institute
P.O. Box 12194
Research Triangle Park, NC 27709

Phone: (919) 541-7429
Fax: (919) 541-6221
E-mail: mdo@rti.org

Molly O'Donovan Dix
Research Triangle Institute
2 Shadow Lane
Amherst, NH 03031

Phone: (603) 672-9051
Fax: (603) 672-8275
E-mail: dix@rti.org

Connectors

The technology developer offers a wide variety of low-cost plug, in-line, and socket connectors for single conductor, single and double shield coaxial cable.



Technology Benefits

The connectors presented on pages 5–13 offer numerous benefits.

- **Secure connection:** Robust antirotation locking systems on some connectors prevent accidental disassembly. Many designs also include asymmetrical ribs that provide high normal forces and withdrawal force higher than insertion, greatly reducing the chances of accidental disassembly.
- **High shield continuity:** With a large connector contact area, the drawn metal parts have little variability in diameter or roundness.
- **Easy assembly:** Tactile feedback aids in blind assembly.
- **Noncorrosive:** The connectors use compatible materials or barrier layers to avoid corrosion. All designs currently use nickel-plated copper contacts.
- **Design compatibility:** Common parts are used throughout the various interconnects.
- **Reliable:** High-pressure contacts and crimp connections, as well as automated soldering, eliminate intermittent connection problems due to vibration.
- **High isolation:** All designs have a dielectric withstanding 1,500 volts.
- **Sealed:** Optional integral boots prevent fluid infiltration.
- **Efficient design:** Only 12 mm of travel is required for a complete connection.
- **Strain relief:** These connectors exceed cable pull-test requirements.
- **Versatile:** All designs and patents allow for male or female signal pins and straight or angled connectors.

Commercial Applications

These connectors could be used in applications where impedance ranges from 50Ω to 125Ω:

- Interconnects for aircraft and marine devices
- Radio antennas for cellular telephones, global positioning systems, and digital satellite radios
- Connectors to link instrumentation and test equipment
- Jumpers to link printed circuit boards
- Cables for televisions and modems
- Audio and video cables for consumer electronics, and broadcast studio equipment
- Disposable sterile cables for medical applications

Specific cable examples include RG-58, RG-59, RG-62/U, RG-62/UM, RD-71/U, and RG-71/UM.

Plug Designs

These connectors are for terminating to coaxial cable.

Plug with Strain Relief, Tactile Feedback, and Assembly Force Differential

With its segmented outside conductive body, this plug has proven itself a price and performance leader in automotive applications. Beyond the benefits described on page 4, this plug provides excellent strain relief via its crimped body. Other benefits of this design include its superior ground continuity, which is provided by six asymmetrical ribs.



These mating plugs currently are in production and have been highly successful in automotive applications.

Hex crimping is used on each of the bodies for strain relief.

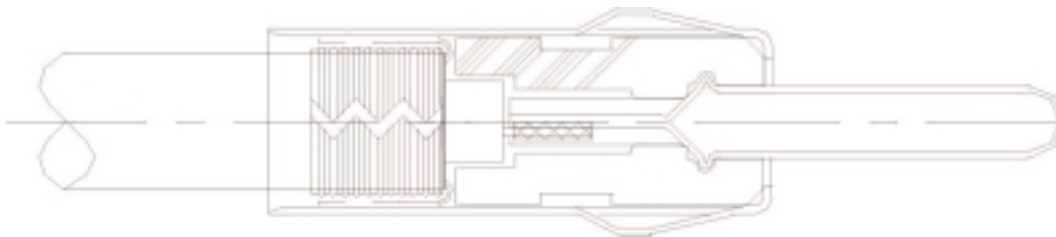

The novel design of the compressible ribs allows the assembly force to be less than the disassembly force.

Plug for Simplified Ground Connection

The unique body of this plug uses insulation displacement for the ground connection, eliminating the need to strip or fold back the shield layer. This reduces assembly steps, time, and cost as well as process variability.

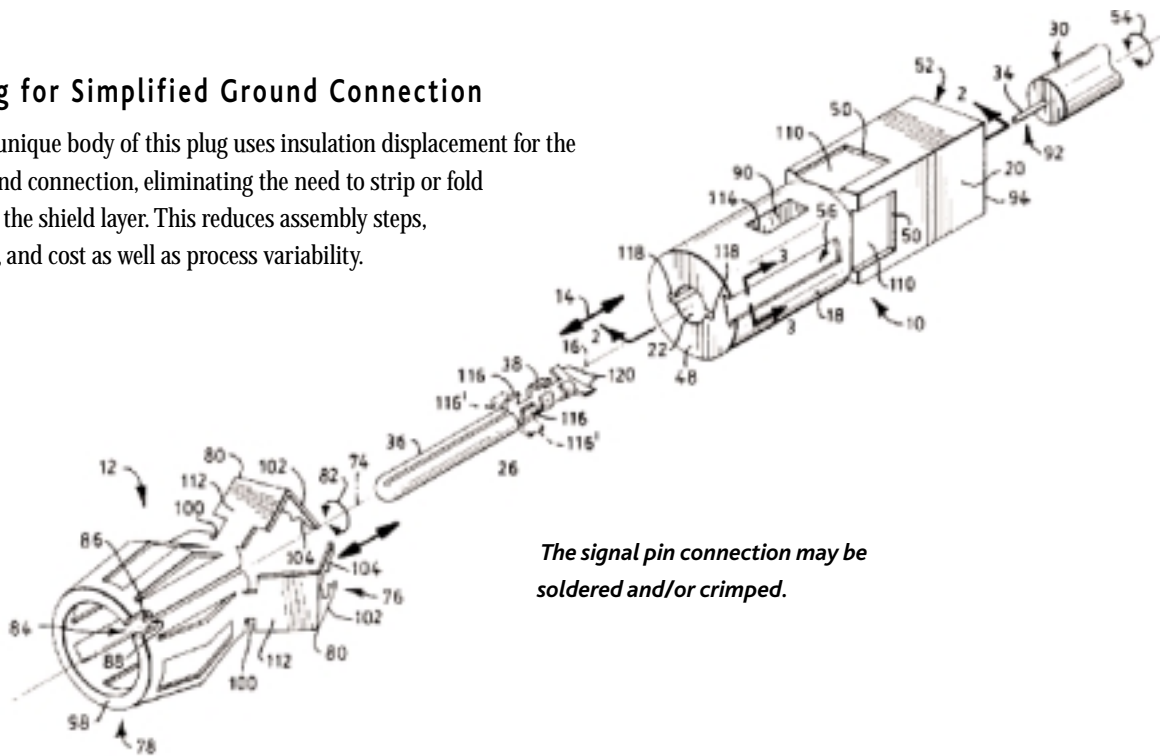

The signal pin connection may be soldered and/or crimped.

Plugs for Simplified Signal Connection

High-pressure spring contacts in the connector body allow the center conductor mechanical and electrical connection to be established simply by inserting the conductor into the body. This eliminates the time, cost, and process variability associated with crimping and/or soldering the center conductor pin. Insulation displacement typically is used for the shield connection, eliminating the need to fold back or even strip the ground insulation.

The hinged insulative housing is closed for cable assembly. During assembly, guide surfaces in the insulative plug housing sandwich the cable signal wire between a compressing tab and ridges in the signal pin.

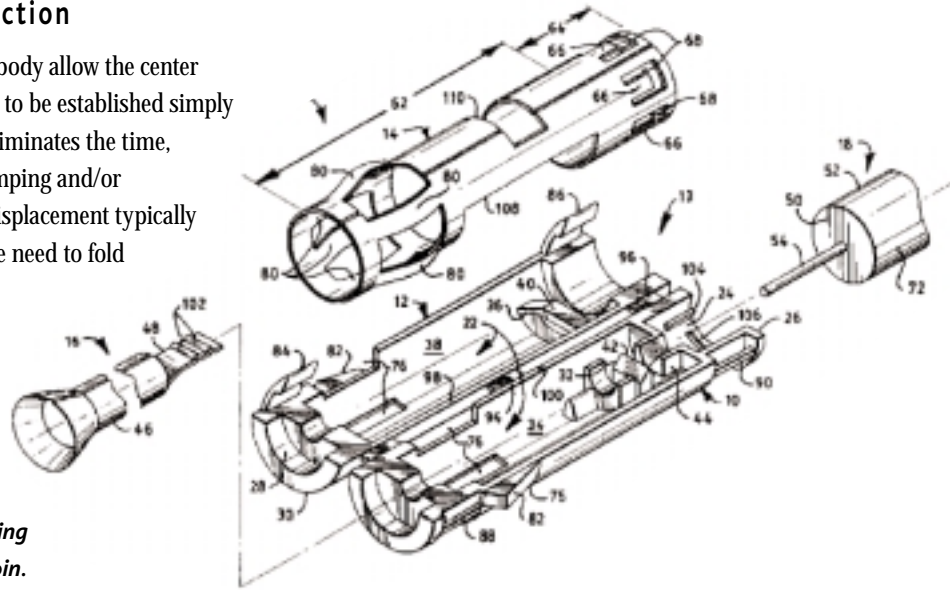

Plugs for Automated Assembly

These plugs require conventional cable stripping, with the ground braid folded back onto the cable. The inside bore of the insulative housing acts as a cam on the tabs of the pin, providing a secure, solderless connection without crimping. Optionally, solder may be used.

This close-up of the signal pin shows how the tabs are shaped to secure the pin mechanically in the bore and to create a high-pressure signal wire contact.

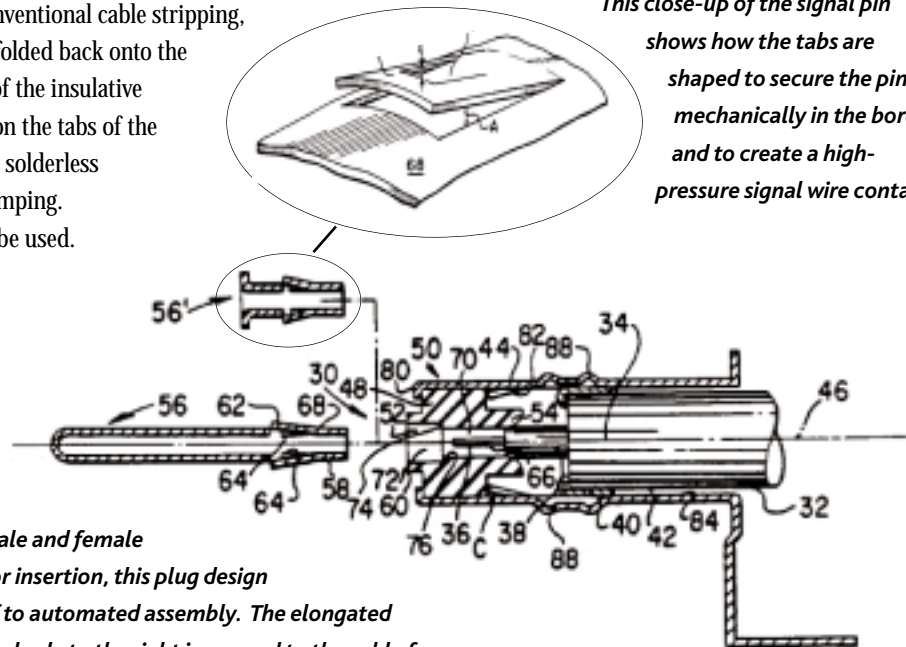

Shown with male and female pins ready for insertion, this plug design lends itself to automated assembly. The elongated plug body to the right is secured to the cable for strain relief and/or for creating an angled plug.

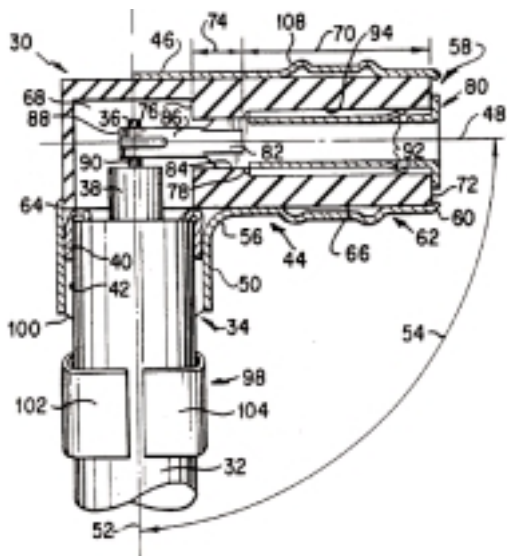

Shown in cross-section, this design provides for an angled plug. As with the straight plug, this design is ideal for automated assembly.

These drawings show how tabs on the pin are cammed against the bore of the insulative housing during assembly.

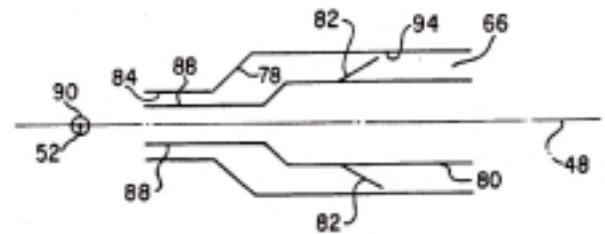

Partially inserted

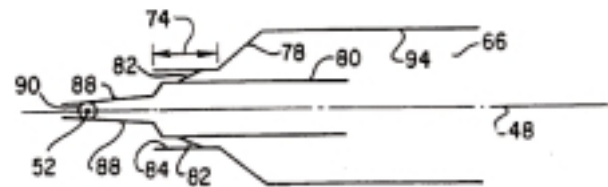

Fully inserted

Reflow Soldered Plugs

The pin of this plug is coated with solder during manufacturing. During cable assembly, the plug is reflow soldered to the center conductor.

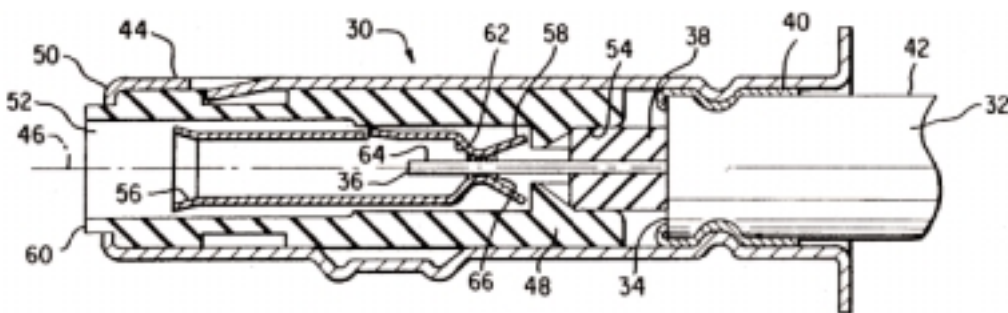

This cross-section view of a typical plug shows conventional cable stripping, with the ground braid folded back onto the cable. The outer shell of the plug is crimped to the ground.

Pins can be manufactured from strips of material with a solder stripe.

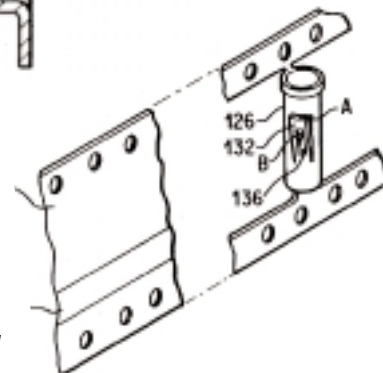

Plug for Field Installations

This small-diameter plug requires that only the ground insulation be stripped—no preparation of the center conductor or folding back of the ground is required. No special assembly tools are required, making the plug ideal for field installations. To assemble, the pin is first latched inside the insulative bushing. Then this assembly is positioned off the central axis of the cable such that the central conductor contacts the outside of the pin. The assembly is inserted into the cable using a screwing motion. The ground is clamped over the cable/pin assembly.

This exploded view shows a female signal pin and the conductive ground shell (bushing between omitted for clarity).

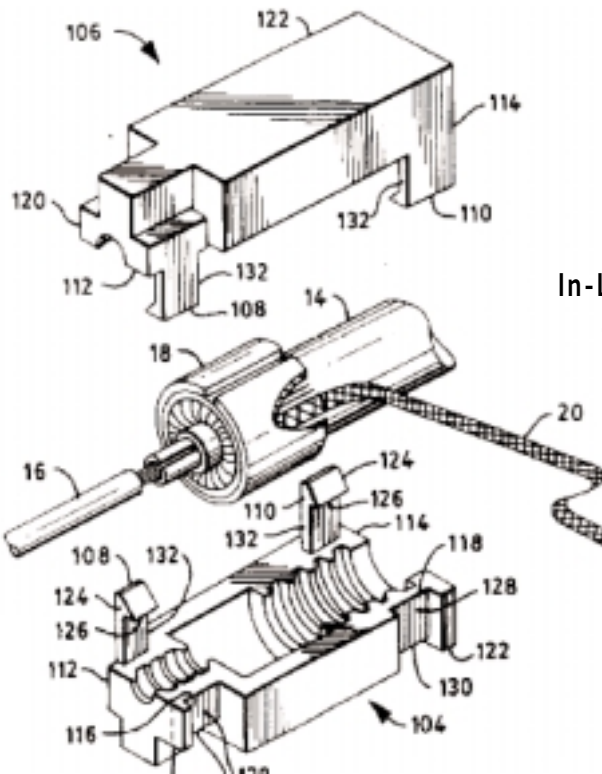
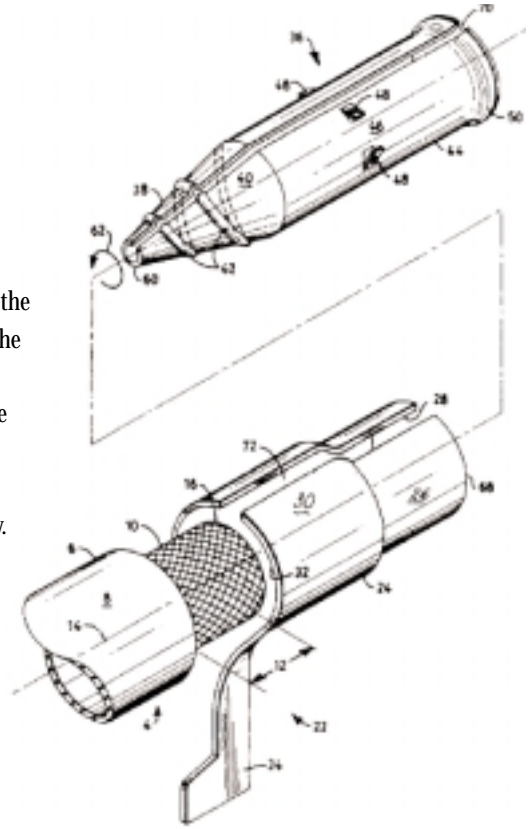

In-Line Connector-to-Terminate Shield

This connector terminates the shield to a ground strap, and the central conductor to a wire. This design was very successful in its original application, providing a connection to an antenna embedded in a windshield.

A partially exploded view of the design.

Additional Plug Components

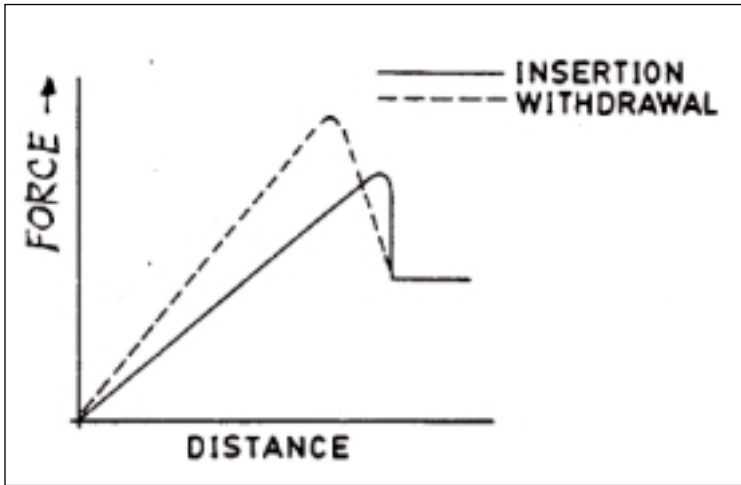

Plug Bodies for Tactile Feedback and Assembly Force Differential

These connector bodies employ compressible ribs that provide a snap-on assembly where the assembly force is less than the withdrawal force. This feature makes the design ideal for blind installations.

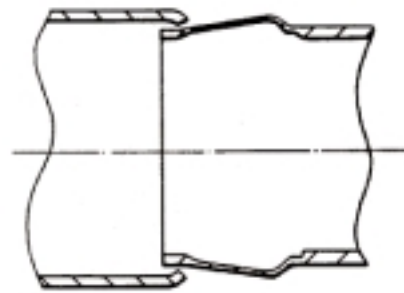

This graph shows insertion and withdrawal force requirements for the connector body. For the original radio antenna socket application, the insertion and withdrawal forces were 13 and 18 Newtons (3 and 4 pounds), respectively. Materials selection and design dimensions could create almost any level of force desired.

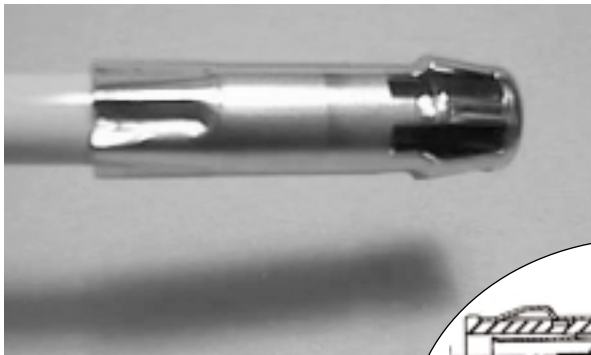

Plug Bodies for Strain Relief and/or Angled Connections

These plug bodies provide strain relief to prevent degradation of electrical connections. In addition to the usual mechanical and electrical connections for the signal and ground, the outside metal shell is hex crimped to the outside of the cable.

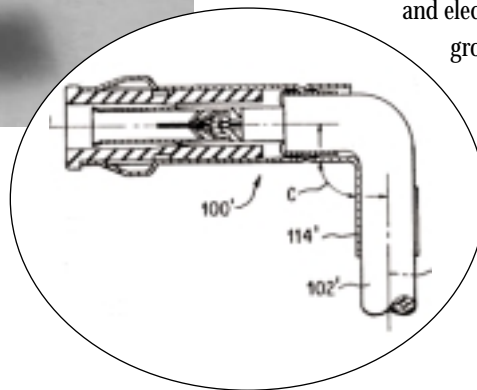

Plug Bodies for Easy Ground Connections

Several of the plug body designs shown here are insulation displacement designs that require no ground preparation. Some designs require only that the ground insulation be stripped (i.e., folding back of ground not required).

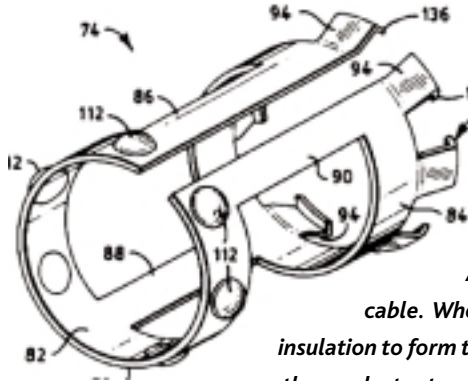

As drawn, this ground body fits over a cable. When positioned, the tabs can pierce the shield insulation to form the ground connection. A sleeve may be slid over the conductor to urge the tabs into the cable and/or hold them in position after the connection is complete.

The shield layer of this cable is prepared simply by removing the outside jacket to expose the ground braid. The ground connector then can be crimped directly onto the braid.

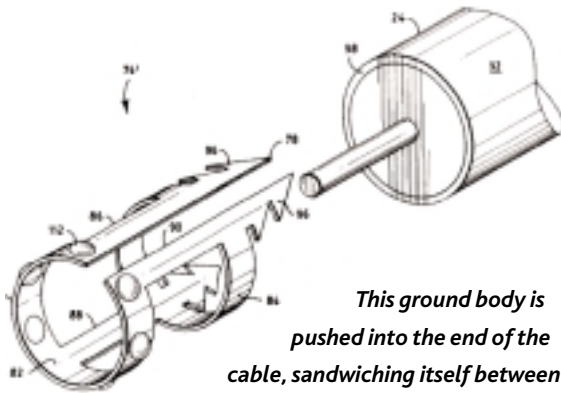

This ground body is pushed into the end of the cable, sandwiching itself between the shield and the insulation.

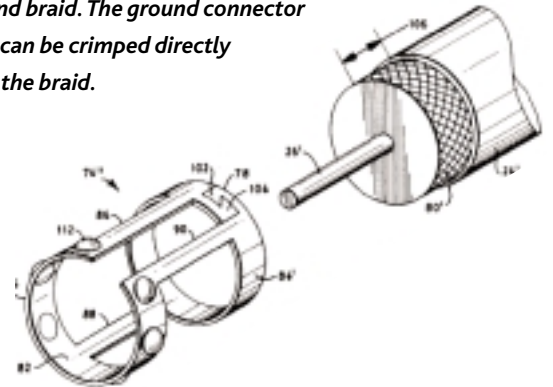

Integral Plug Seals

These simple seals provide a barrier against fluid infiltration and are compatible with most of the connectors presented in this document.

The front seal is an elastomeric sleeve, which seals this plug to a mating socket. The rear seal is heat-shrink tubing, which seals the plug body to the cable.

Connector Latches

These latches are easy to assemble and disassemble in high-speed environments. They also prevent unintentional disconnections from inadvertent axial forces.

This latch design uses beams with pins that ride on ramped surfaces of the mating connector.

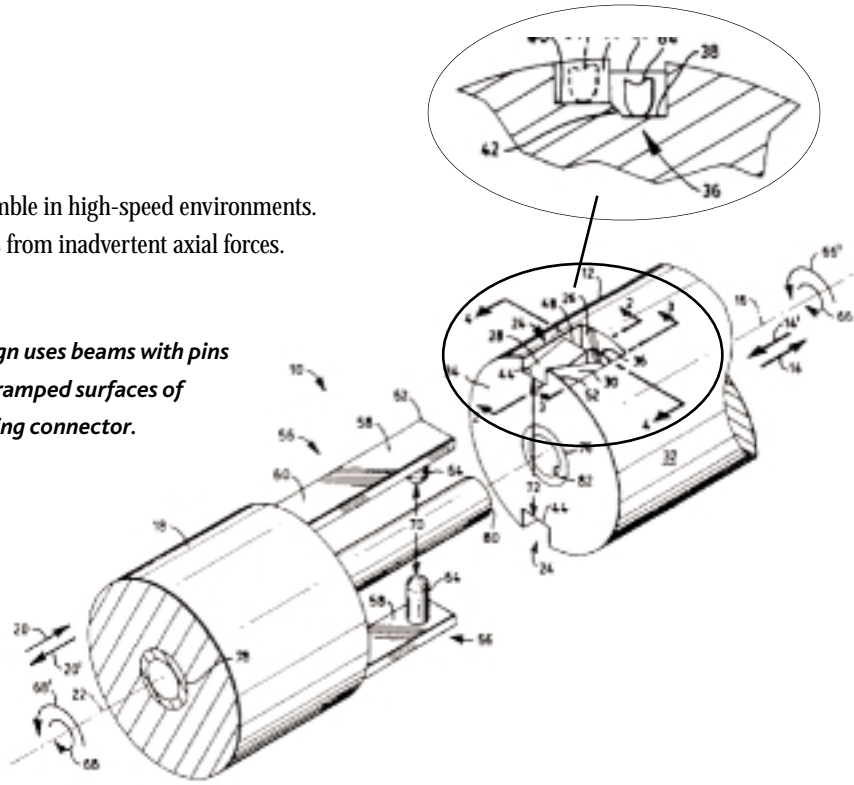

This connector position assurance (CPA) latch ensures that a pair of mated in-line connectors remains connected. The outside contours of the connectors match the contours inside these latch halves.

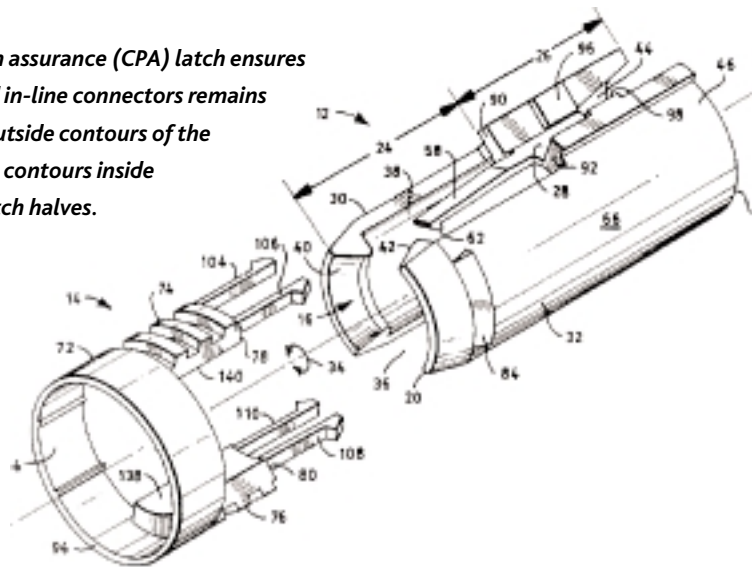

Sockets

These connectors receive a coaxial plug and connect it to a circuit board or another interface. None of the designs requires solder—snap fits and bendable tabs secure the housing and contacts. All designs provide tactile feedback to ensure a positive assembly.

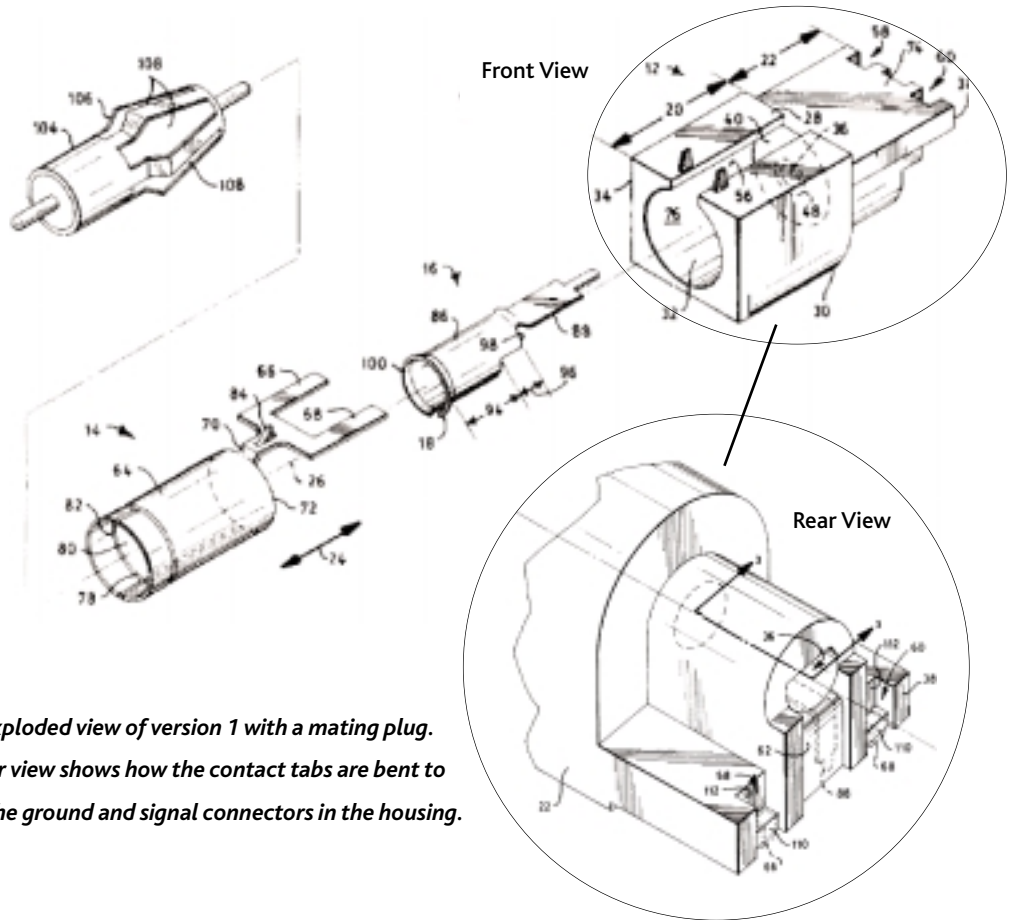

*Exploded view of version 1 with a mating plug.
The rear view shows how the contact tabs are bent to secure the ground and signal connectors in the housing.*

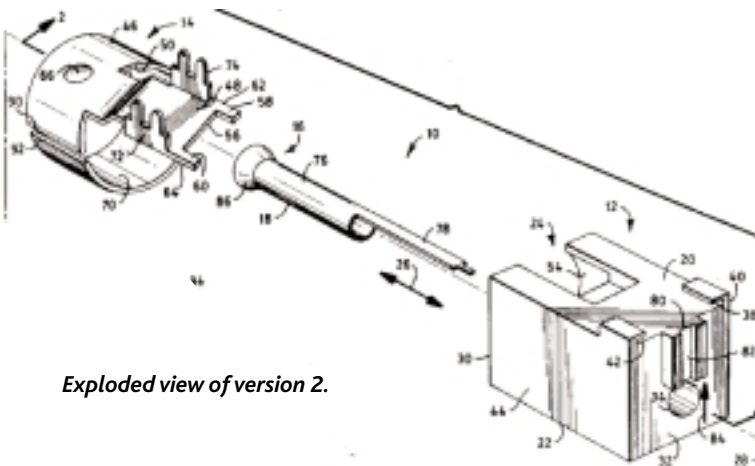

Exploded view of version 2.

Exploded view of version 3 with a mating plug.

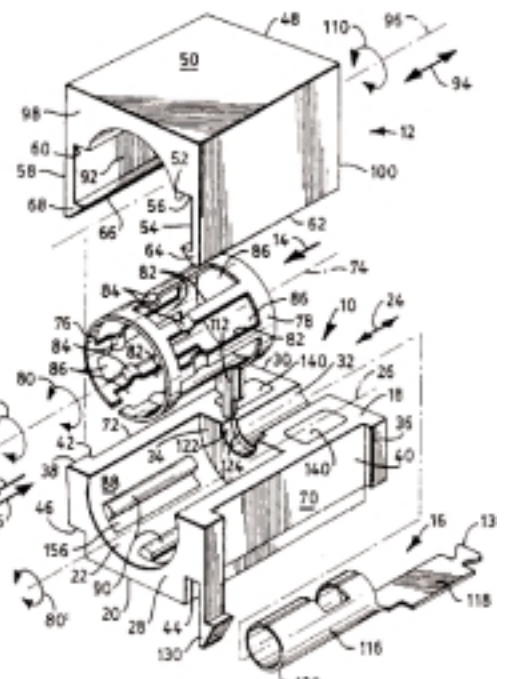

Sockets with Insulative Housing

These three socket designs are based on an insulative exterior housing. Each has features to prevent axial and rotational motion of the plug relative to the socket.

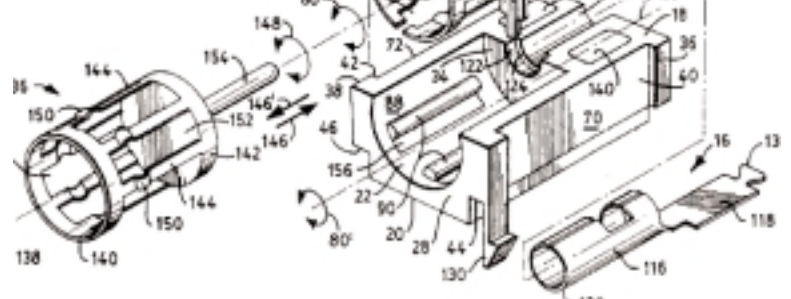

Socket with Grounded Conductive Housing

This socket design is based on a grounded conductive exterior housing. The socket has features to prevent axial and rotational motion of the plug relative to the socket.

This simple and compact design is ideal for applications where a grounded conductive housing is desired.

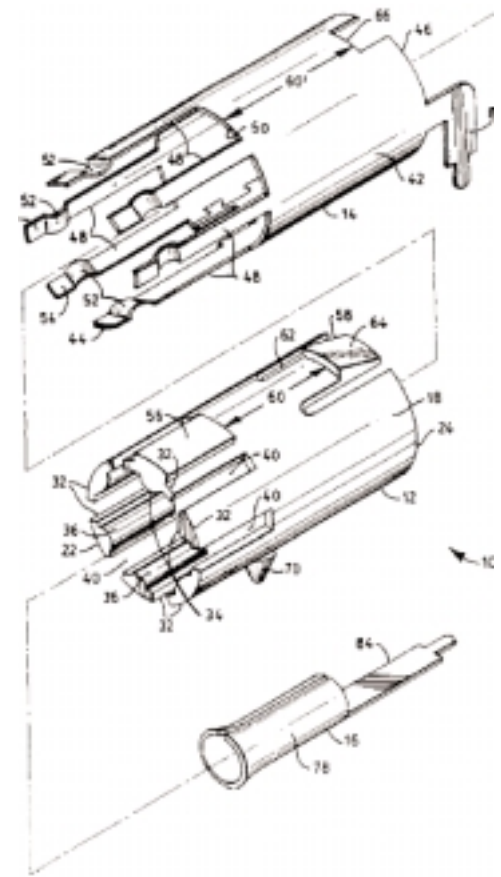

Conductive ground plate

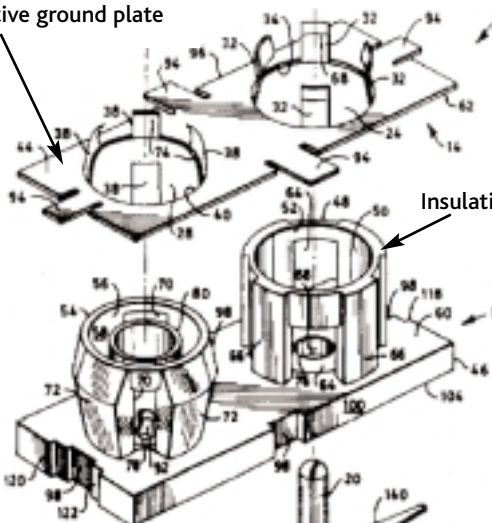

Insulative housing

A duplex socket assembly can be fabricated from four parts.

Signal contacts

Duplex Socket for Panel Mounting

This simple socket assembly can be easily and securely attached to a panel. The design shown here uses male and female sockets to prevent crossed connections, but any connector combination could be selected.

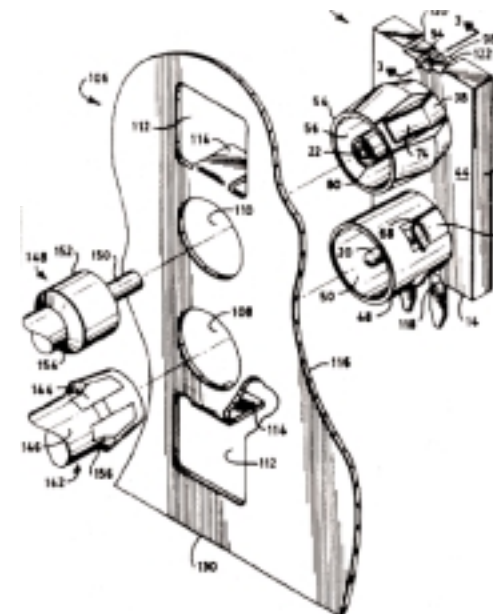

This drawing shows (from right to left) the assembled socket, panel, and plugs. The tabs on the panel fit into the grooves of the socket and are bent around the rear of the socket housing, providing a firm mount. An alternate attachment method using c-clips is ideal for installations where tabs cannot be used (e.g., the socket is mounted close to the edge of the panel).

Cable Accessories

In addition to the many connector designs described earlier, the technology developer offers several cable accessory designs for licensing. These accessories may be useful for coaxial cable, wire bundles, tubing, and many other applications. The specific benefits and potential applications are provided for each technology.

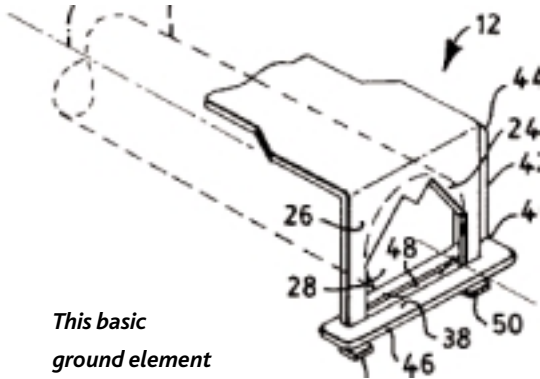

This basic ground element consists of a forked member to pierce the jacket of the cable with an integral gate to secure the cable in the device.

Cable Ground and Support

This simple element is useful in applications where an inexpensive redundant ground and/or cable support are desired. The designs shown here can be fabricated from a single piece of sheet metal.

Benefits

- **Low cost:** This element can be stamped from a single piece of sheet metal.
- **Reliable:** The design ensures a positive ground.

Applications

This element is useful for any shielded cable application where an in-line ground is desired:

- Two-way radio antenna installations in service trucks, heavy equipment, boats, and aircraft
- Instrumentation, audio, and video cables
- Cables for televisions and modems

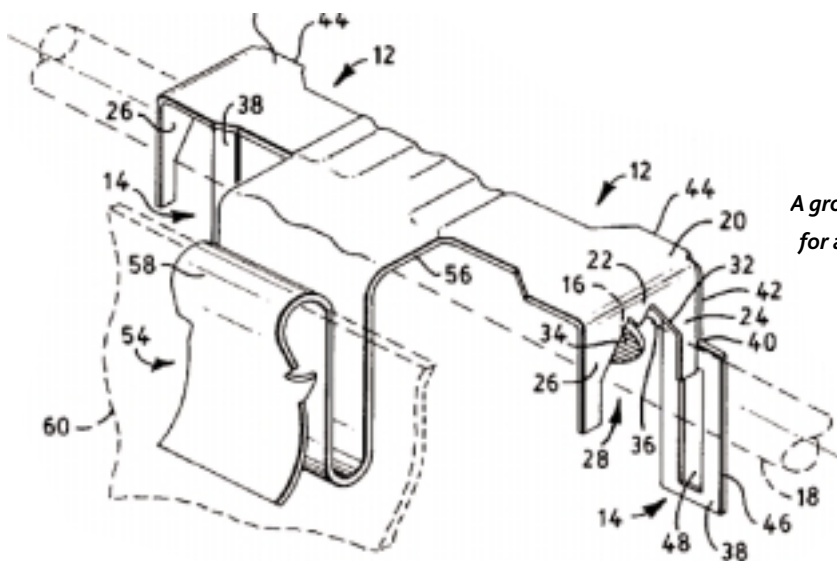

A grounding cable support can be fabricated for attachment to sheet metal.

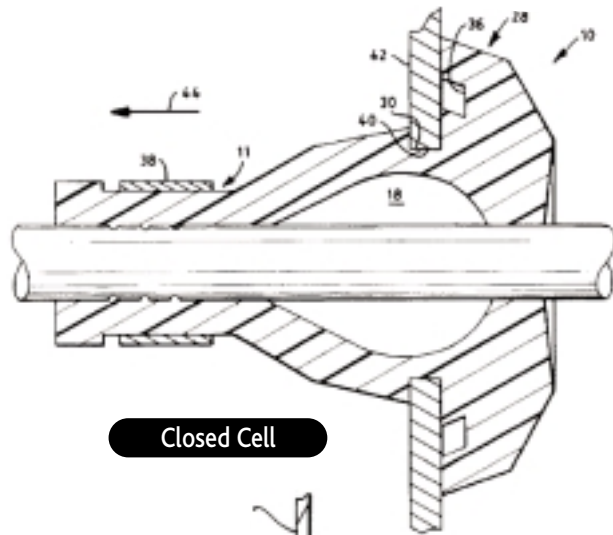

Closed Cell

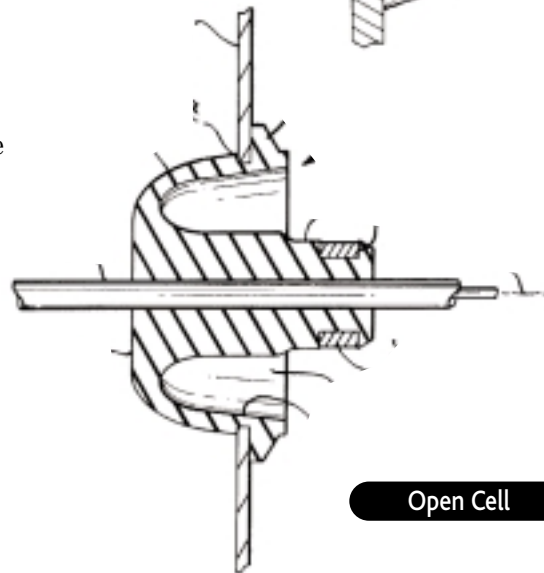

Open Cell

Low Insertion Force Grommets

These grommets are designed to be crimped to a cable and pulled with the cable through an aperture until seated. Prior grommet designs required high insertion forces, which sometimes damaged the cable. These grommets improve sealing and greatly reduce the installation force for a typical automotive antenna cable to between 15 and 20 pounds.

Benefits

- **Low insertion force:** Cable breakage problems and installer fatigue are reduced or eliminated.
- **Low cost:** This one-piece design can be inexpensively molded.
- **Proven:** This design has been used successfully in millions of vehicles.
- **Secure seal:** This design passes stringent water intrusion tests.

Applications

These grommets are useful for any application where cable, wire, or tubing needs to be sealed and supported while passing through a bulkhead or other sheet of material:

- Lawn and garden equipment
- Boats and aircraft
- Tractors, forklift trucks, bulldozers, and cranes
- Industrial electrical and mechanical equipment

The hollow space of the grommet collapses during installation to allow seating to occur with much less force than prior solid grommets. The closed cell design is ideal for applications where removal for service is a priority since no foreign matter can enter the cell during service.

Angled Cable Clamps

These clamps can easily be added to a connector or along the length of a cable to provide an angled connector or in-line cable bend. They attach to the cable in two sections. The first section typically is fabricated from sheet metal and is crimped onto the cable. A length of the metal attaches the first section to the second section, allowing for the angle between the sections to be adjusted. The second section typically is molded from a polymer.

Benefits

- **Low cost:** These simple designs are easy to fabricate and install.
- **Reliable:** The latches are fail safe.

Applications

These clamps benefit any connector or in-line cable, tubing, wire, or wire bundle application where a small turn radius is needed:

- Audio and video cables
- Pneumatic tubing for instrumentation
- Vacuum hoses in construction and industrial equipment
- Antennas in boats and aircraft

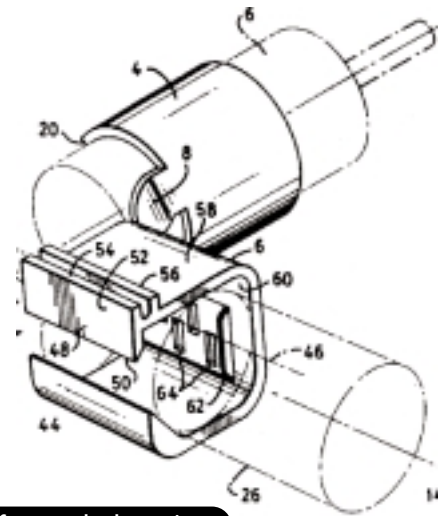

Interference-lock retainer

These drawings show two novel cable clamp designs. For the interference-lock design, the cable may be pushed into the opening of the clamp, forcing the T-shaped section to rotate counter-clockwise and admit the cable. When the cable is fully inserted, the T-section returns to its original position. Reverse force on the cable drives the T-section clockwise and presses it against the ridge, retaining the cable.

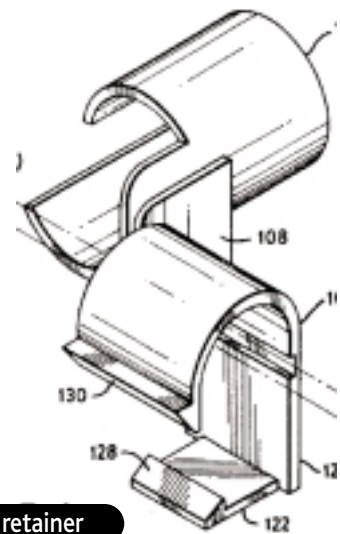

Snap-lock retainer

Alignment Guides for Right Angle Duplex Sockets

These guides were developed to align a mating pair of plugs with sockets.

Benefits

- **Low cost:** These simple designs can be produced and installed with little investment.
- **Reliable:** These designs maintain cable orientation.

Applications

These alignment guides benefit any right-angle duplex electrical connector where space is limited:

- Audio and video cables
- Antennas in boats and aircraft
- Industrial electronic and electrical equipment

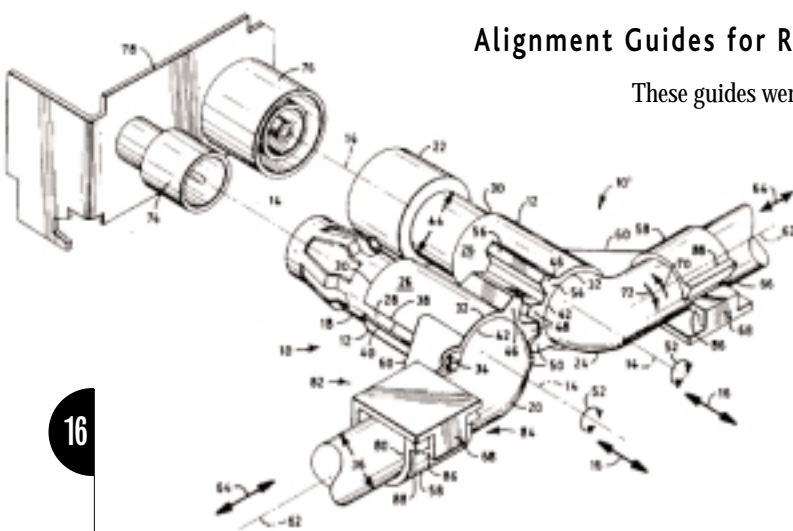

This design enables the angular orientation of one connector to be adjusted relative to another conductor.

This alignment guide design prevents inadvertent rotational movement of the plugs by allowing for a connection only in a predetermined fixed orientation.

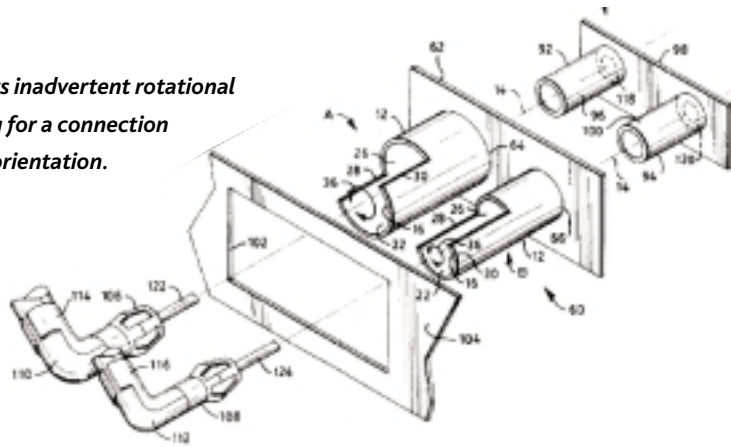

Cable Anchors to Eliminate Taping

These designs were developed as improvements over tape-wrapped cable anchors. Consistency and quality also are improved by eliminating time-consuming and costly tape wrapping.

Benefits

- **Low cost:** These simple designs can be easily and inexpensively molded and installed.
- **Reliable:** The locking cable retainers eliminate the need for tape adhesive, which degrades over time or with heat exposure.
- **Versatile:** The wide range of designs allows for either totally static or limited-motion anchoring.

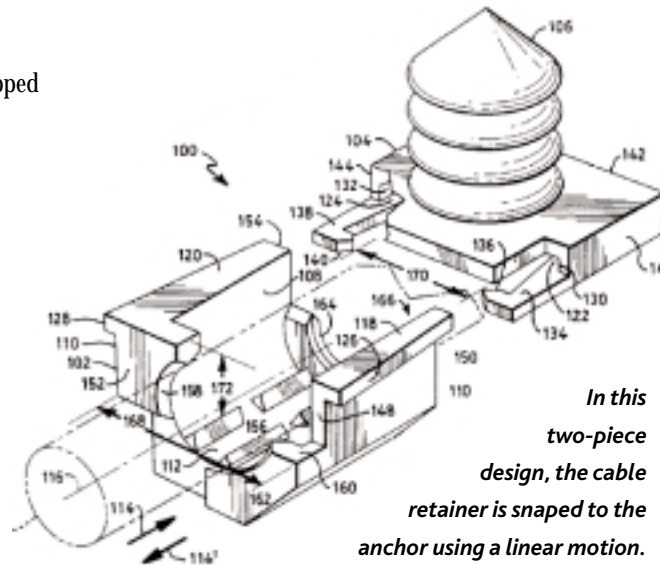

In this two-piece design, the cable retainer is snapped to the anchor using a linear motion.

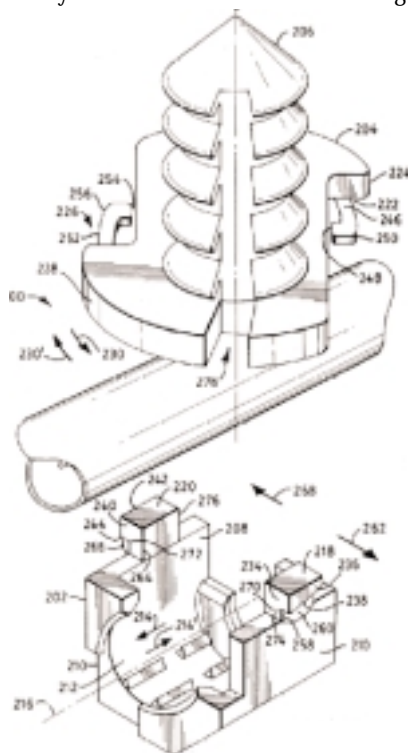

Applications

These designs can be used for a single cable as well as for a bundle of wires or hoses in a variety of applications:

- Lawn and garden equipment
- Boats and aircraft
- Tractors, forklift trucks, bulldozers, and cranes
- Industrial electrical and mechanical equipment

Twisting this two-piece design snaps the cable retainer to the anchor.

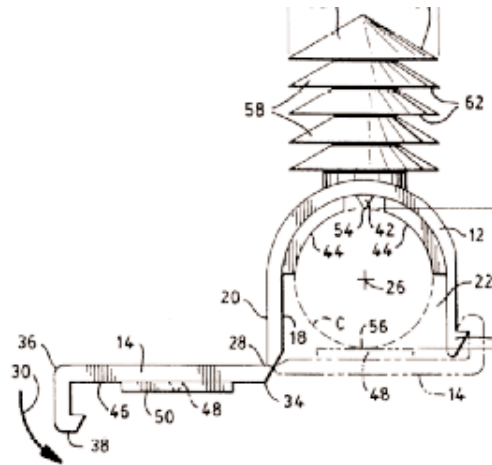

This one-piece design uses a hinged locking cable retainer.

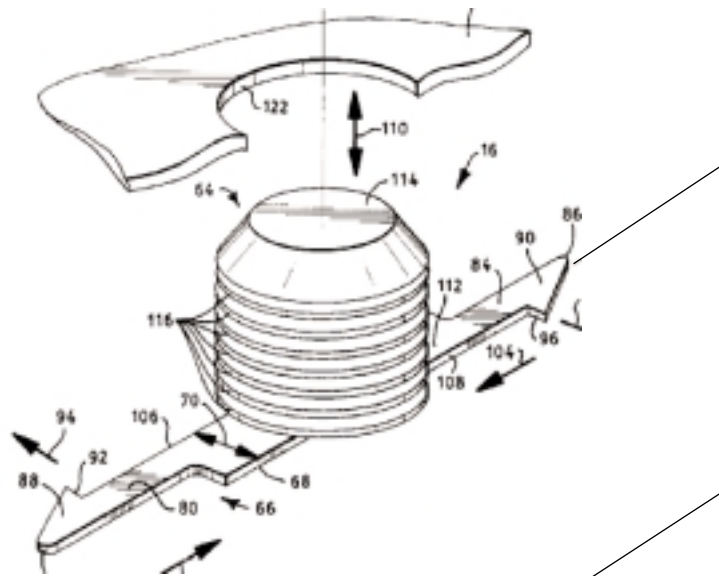

This two-piece design is ideal for installations where some limited axial motion of the anchored cables is desired for reduced tolerances, servicing, or other purposes. After the cable retainer is latched into the anchor, stops on the anchor provide a specific range of motion while otherwise fixing the cable.

